

Operator's Manual

EXCAVATOR/BACKHOE BRUSH CUTTERS

Standard-Duty X Series

3600X

4200X

4800X LF | 4800X SF | 4800X HF

WHY READ THIS MANUAL?

Before operating your new Brush Wolf brush cutter, read this entire manual to understand **1) safety precautions, 2) operating instructions, and 3) maintenance schedule** to help keep you safe and your equipment running smoothly for years to come.



TAKE A MINUTE TO WRITE DOWN THE FOLLOWING INFORMATION
FOR FUTURE SERVICE, REPAIR, AND WARRANTY INQUIRIES.

OWNER REFERENCE INFORMATION

DATE OF PURCHASE _____

MODEL NO. _____

SERIAL NO. _____

DEALER NAME _____

SALES REP NAME _____

DEALER PHONE NO. _____

DEALER EMAIL _____

DEALER ADDRESS _____

THANK YOU

Welcome to the Brush Wolf family!

You've made a smart choice! We hope you love your brush cutter as much as we love making it. If you have any issues, please contact us at any time. We're here to help.

Brush Wolf

218-692-1050

info@brushwolf.com

www.brushwolf.com

WHAT'S INSIDE

SAFETY FIRST!	2-3
OPERATING YOUR BRUSH CUTTER	4-6
MAINTENANCE	7-9
TROUBLESHOOTING	10
HOW TO REPLACE BLADES	11
PARTS SECTION	
3600X	14-15
4200X	16-17
4800X LF 4800X SF	18-19
4800X HF	20-21
WARRANTY INFORMATION	22

SAFETY FIRST!

FOR YOUR SAFETY, READ THESE INSTRUCTIONS.

The following safety instructions are provided to alert you to precautions that, if not followed, may cause serious injury to yourself or to others. Please read these instructions completely. Brush Wolf cannot cover every incident that might be a hazard. Extreme caution should be used at all times. Only use your Brush Wolf brush cutter for the purpose for which it has been designed.

SITE INSPECTION

Before operating your brush cutter, carefully inspect the area to be cleared. Remove any items that may be picked up and thrown by the cutting blades, such as wire, pipes, rocks, etc. Mark objects that are too large to move. This is an important step to avoid personal injury, damage to property, the brush cutter, or your excavator/backhoe. If an object is struck while operating the brush cutter, immediately shut down power to both the brush cutter and the excavator/backhoe. Any damage should be corrected and tested before the continuation of cutting.

EXCAVATOR/BACKHOE AUXILIARY HYDRAULIC FLOW

Check the specifications of your brush cutter's rated gallons per minute (GPM) to correctly match the hydraulic flow of your excavator/backhoe to ensure proper operation.

EQUIPMENT INSPECTION

Disconnect the unit from the excavator/backhoe. To inspect or to make repairs under the cutter deck, always block the unit securely to prevent accidental release of the lift mechanism.

Inspect all hydraulic connections to ensure they are tight, and hoses and shields are in good condition before applying pressure. Hydraulic fluid can escape under pressure and may cause serious injury or death. If this type of injury occurs, seek medical attention immediately.

SAFETY GEAR

Wear safety goggles, hearing protection, and a hard hat. Only operate the excavator/backhoe behind a shatterproof forestry-rated door and cab.

DO NOT operate near bystanders, vehicles, pets, livestock, or buildings. Objects may discharge while cutting with the brush cutter and has the potential to cause serious injury.

DO NOT operate the brush cutter until everyone on your work crew is alerted to the dangers of walking up to the brush cutter while in operation.

DO NOT operate the brush cutter in conditions with poor visibility.

DO NOT operate while intoxicated or if taking medications that may impair your senses or reactions.

DO NOT allow children to operate the brush cutter. Only individuals with excavator/backhoe experience who are well acquainted with the rules of safe operation should be allowed to operate the brush cutter.

DO NOT operate the excavator/backhoe without a shatterproof forestry-rated door and cab.

DO NOT place hands, feet, or other objects under the deck while the brush cutter is in operation.

DO NOT allow anyone or any item on top of the mower deck while in operation.

DO NOT expose the underside of the blades towards the cab while in operation.

DO NOT continue operation if an unexpected object is struck. IMMEDIATELY shut down power to both the brush cutter and the excavator/backhoe. Disconnect the hydraulic couplers from the power source. Evaluate the damage, repair, and then test the unit before operation.

DO NOT leave the brush cutter unattended while in a raised position. Always make sure both the runners are placed firmly on the ground and shut down the excavator/backhoe.

DO NOT attempt to straighten blades. Order replacement blades if blades are bent, cracked, or damaged.

OPERATING YOUR BRUSH CUTTER

▶ START HERE

Verify your excavator's/backhoe's hydraulic flow to ensure it is within the brush cutter's rating range. The brush cutter's gallons per minute (GPM) rating is located on the serial tag of the brush cutter.

FIGURE 1: SERIAL TAG

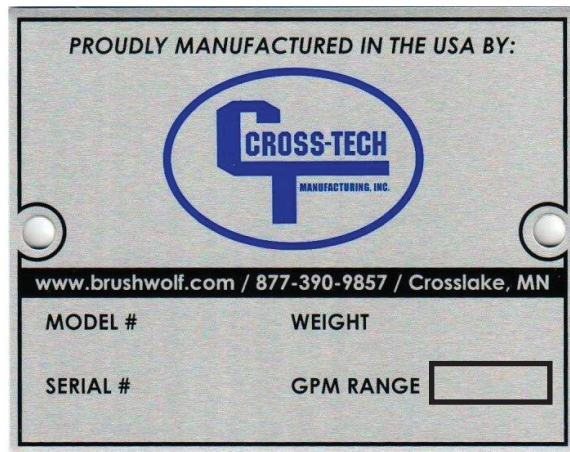

▶ IMPORTANT: CHECK THESE ITEMS PRIOR TO OPERATING

CHECK BLADES

Inspect blades to ensure they are sharp, tightened correctly, and intact. Look for damage, dullness, and cracks. See page 8 for details.

CHECK NUTS & BOLTS

Tighten the 1) blade carrier to the gearbox, 2) blade bolts/nuts, and 3) hydraulic motor mount nuts to torque specification listed on page 9.

CHECK HYDRAULIC FLUID

A low level could indicate a leak and require a closer inspection of your unit. See page 8 for details.

INSPECT THE DRIVE COMPONENTS

Remove any foreign material.

► CONNECTING THE BRUSH CUTTER

- 1) Ensure pins or quick couplers are properly connected from the brush cutter to your excavator/backhoe.

NOTE: All Brush Wolf brush cutters come from the factory with the female flat faced coupler on the pressure line and the male coupler on the return line.

- 2) Inspect the hydraulic couplers and wipe off water, dust, or any debris which can damage hydraulic components. Once cleaned, connect the couplers from the cutter to the auxiliary hydraulic system on the excavator/backhoe. If you have a HIGH FLOW excavator/backhoe and brush cutter, attach the case drain to the excavator/backhoe. Twist the collars of the quick connect couplers to secure the hydraulic connections. Do not operate the brush cutter on high flow hydraulics (over 30 GPM) unless the brush cutter is equipped with a high flow motor as this may cause damage to the motor and void the warranty.
- 3) Make sure the hoses are routed in a way that allows the head to make a full range of motion. If hoses are too long and pinching or binding, they can be made shorter by loosening the hose bracket and feeding additional hose length back to the cutter deck.
- 4) Confirm all safety measures have been completed per the Safety First! section (pages 2-3). Most importantly, make sure the area is clear of people and pets.

FIGURE 2: HOSE ENDS

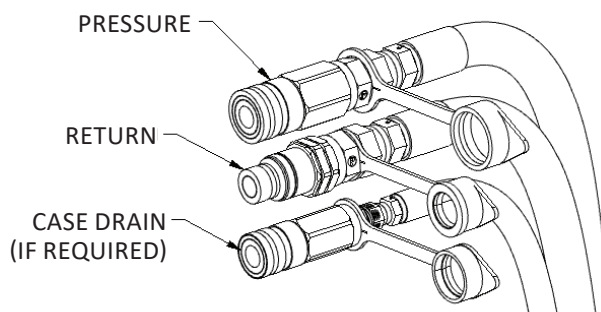

▶ OPERATING STEPS

- 1) Enter the shatter-proof cab door, engage the seat belt, release the brake, and start the engine. The runners of the brush cutter should be as close to the ground as possible.
- 2) Slowly apply hydraulics to the brush cutter and increase the engine speed to high idle. Make sure the unit is operating smoothly before moving the excavator/backhoe forward.
- 3) Check for proper blade rotation. **Blades should spin COUNTERCLOCKWISE as viewed from above** (see Figure 3). If rotation is reversed (clockwise), either inverse the flow from your machine or switch the QD couplers on the hose ends.

When temperatures are below zero, allow additional time for hydraulic fluid to warm up.

- 4) **Maintain excavator/backhoe speed** appropriate for the volume of brush to prevent stalling.
- 5) Stay alert for drop-offs, rocks, holes, abandoned wells, and septic tanks. Do not operate or drive across a steep embankment as this may cause a rollover and possible injuries or death.
- 6) To **cut large diameter brush and trees**, move forward slowly to make the cut.

FIGURE 3: BLADE ROTATION

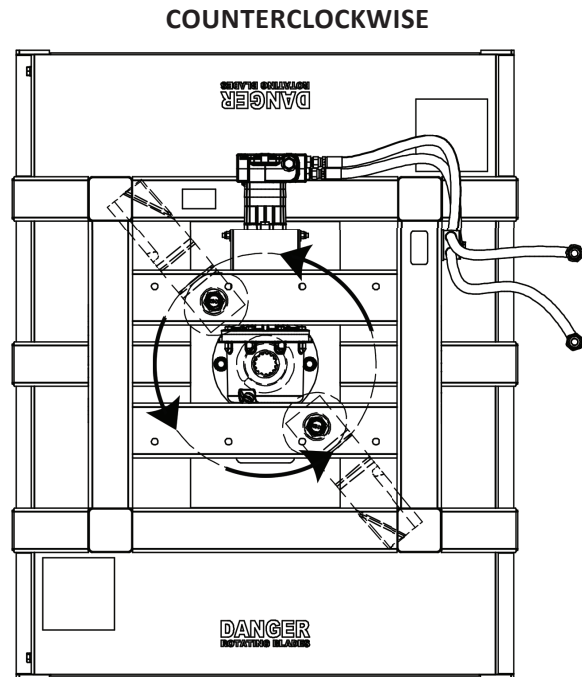

▶ WHEN DONE CUTTING

When done, lower lift arms, make sure the cutter is placed flat on the ground, throttle down on the excavator/backhoe, and shut off the hydraulic flow to the brush cutter. Stop the engine and engage the parking brake before leaving the cab. **Noise at shut down is normal.**

DISCONNECTING HOSES:

To disconnect hoses, use proper hand protection as the couplers may be hot. Always replace caps on hoses once removed to prevent contamination.

MAINTENANCE

BRUSH WOLF BRUSH CUTTERS ARE BUILT TO STRICT STANDARDS AND WILL DELIVER YEARS OF DEPENDABLE SERVICE WHEN YOU FOLLOW THESE MAINTENANCE GUIDELINES...

► MAINTENANCE SCHEDULE

See pages 8-9 for details.

ITEM	BEFORE EACH USE	DAILY OR EVERY 8 HOURS	AS NEEDED
Blades	Inspect		
Gearbox Lubricant	Check Oil		
Blade Bolt/Nuts		Torque to 775 ft-lbs	
Gearbox Castle Nut		Torque to 450 ft-lbs	
Gear Mounting Bolts		Torque to 275 ft-lbs	
Hydraulic Motor Mount Bolts		Torque to 75 ft-lbs	
Block (high flow units only)		Torque to 420 ft-lbs	
Shear Bolt Grade 2		Torque to 75 ft-lbs	
Hoses & Hose Safety Shield	Inspect		
Gearbox Shaft	Inspect		
Brush Cutter			Clean

CAUTION: Perform maintenance on a level surface with the unit firmly on the ground and blocked. Shut down the excavator/backhoe and remove hydraulic hoses from the power source.

DO NOT loan your brush cutter to another excavator/backhoe owner. The potential exists for hydraulic contamination and could shorten the life of your excavator/backhoe or the hydraulic motor on your brush cutter. Contamination of the hydraulic motor voids the warranty.

► BEFORE EVERY OPERATION

❑ INSPECT BLADES

Inspect blades before each use to ensure they are sharp, tightened correctly, and intact. Look for damage, dullness, and cracks. Blades should rotate freely and be clear of obstructions. Replace the entire set of blades if damaged.

CAUTION: Always replace the entire set of blades. Never weld or straighten damaged blades, as loss of blade integrity may result.

❑ CHECK HYDRAULIC HOSES AND HOSE SAFETY SHIELD

Check for wear, damage, or leaks. Replace if damaged.

❑ INSPECT THE DRIVE COMPONENTS

Inspect before each use and remove foreign material.

❑ CHECK THE GEARBOX FOR PROPER LUBRICANT

To check the lubricant level, remove the pipe plug from the side of the gearbox. The lubricant should be the same level as the plug (see Figure 4). If low, add 85W-140 gear lube.

IMPORTANT: DO NOT overfill as too much lubricant may rupture the gearbox seals.

FIGURE 4: GEARBOX LUBRICATION DIAGRAM

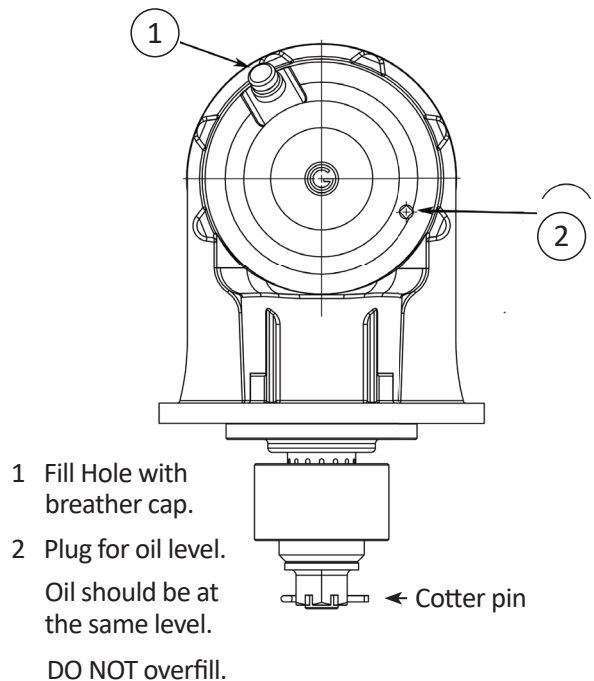

► BEFORE EVERY OPERATION

CHECK NUTS & BOLTS

Every Brush Wolf brush cutter is tested at the factory and all nuts and bolts have been tightened to specifications. We recommend you check the nuts and bolts after the first 4 to 6 hours of operation; then daily or every eight (8) hours.

Tighten the nuts that secure the blades to the blade carrier every eight (8) hours. Torque the nuts to 775 ft-lbs with a 1-11/16" socket wrench. The nuts are located under the access plate on the top of the blade carrier (see Figure 5).

FIGURE 5: ACCESS COVER

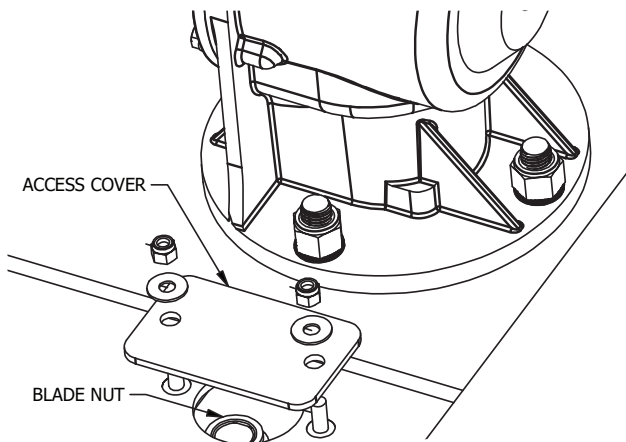

Also, tighten the castle nut holding the blade carrier to the output shaft of the gearbox. Torque to 450 ft-lbs with a 1-1/2" socket wrench. Insert cotter pin through hole on gearbox output shaft (see Figure 4).

Tighten gear mounting bolts daily or every eight (8) hours. Torque the bolts to 275 ft-lbs.

Tighten hydraulic motor mount bolts daily or every eight (8) hours. Torque the bolts to 75 ft-lbs.

Tighten block (high flow units only) daily or every eight (8) hours. Torque to 420 ft-lbs.

Tighten shear bolt grade 2 daily or every eight (8) hours. Torque to 75 ft-lbs.

Shear bolt protection (also known as butter bolt) at the motor coupler. It is recommended to carry additional shear bolts (1/2-13 x 3" GRD 2) obtained at most hardware stores. **Only use grade 2 when replacing.**

► AS NEEDED

- CLEAN THE BRUSH CUTTER** as needed and look for potential damage or obstruction that could result in poor performance.
- Make sure all **SAFETY DECALS** are visible.

TROUBLESHOOTING

CONSULT YOUR DEALER OR CONTACT BRUSH WOLF FOR ANY QUESTIONS OR ADDITIONAL HELP.

ISSUE	POTENTIAL CAUSES
Loss of Power	<ul style="list-style-type: none">• Low hydraulic fluid level• Overheated hydraulic fluid*• Contaminated hydraulic fluid*• Low gearbox lubricant level• Broken gearbox/motor shear pin• Missing input shaft key
Excessive Unit Vibration	<ul style="list-style-type: none">• Dull, broken, or damaged blades• Bent gearbox shaft• Blade carrier out of balance• Loose nuts and bolts• New blade or bolts matched with worn blade or bolts• Wire or rope wrapped around blades
Leaking Oil	<ul style="list-style-type: none">• Loose hydraulic connections• Ruptured hydraulic motor seals• Bent gearbox shaft• Loose or missing motor drain plug

*May damage hydraulic motor and void warranty.

HOW TO REPLACE BLADES

Perform replacement on a level surface with the brush cutter blocked off the ground. Shut off the hydraulic power supply and disconnect hydraulic couplers.

- 1) Take off the access cover (see Figure 5 on page 9) by removing the nuts and washers.
- 2) Through the exposed access hole, rotate the blade carrier to line up the nut of the blade for access.
- 3) Insert a 1-11/16" socket through the access hole and remove the nut and drop the bolts. **Caution:** once nuts are removed, blades will fall to the ground if not supported.
- 4) Clean new bolts, lock-nuts, and washer with cleaner/degreaser. Prior to assembly, ensure all hardware is dry and free of any contaminants including the carrier assembly.
- 5) Use Primer Loctite on the bolts and nuts according to the directions on the label. Apply Loctite #243 to the first 10 bolt threads to ensure coverage.
- 6) Assemble the new blade, the bolt, and the nut to the carrier. The blade carrier cuts in one direction, counterclockwise.
- 7) Torque the blade bolts to 775 ft-lbs. using a 1-11/16" socket.
- 8) Confirm the blade carrier rotates freely and is clear of any obstructions.
- 9) Reinstall the access cover plate.

PARTS SECTION

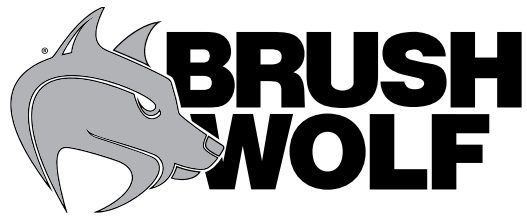

**ONLY USE GENUINE OEM PARTS
ORDER PARTS DIRECTLY
FROM BRUSH WOLF
BY CALLING 218-692-1050**

PARTS: 3600X

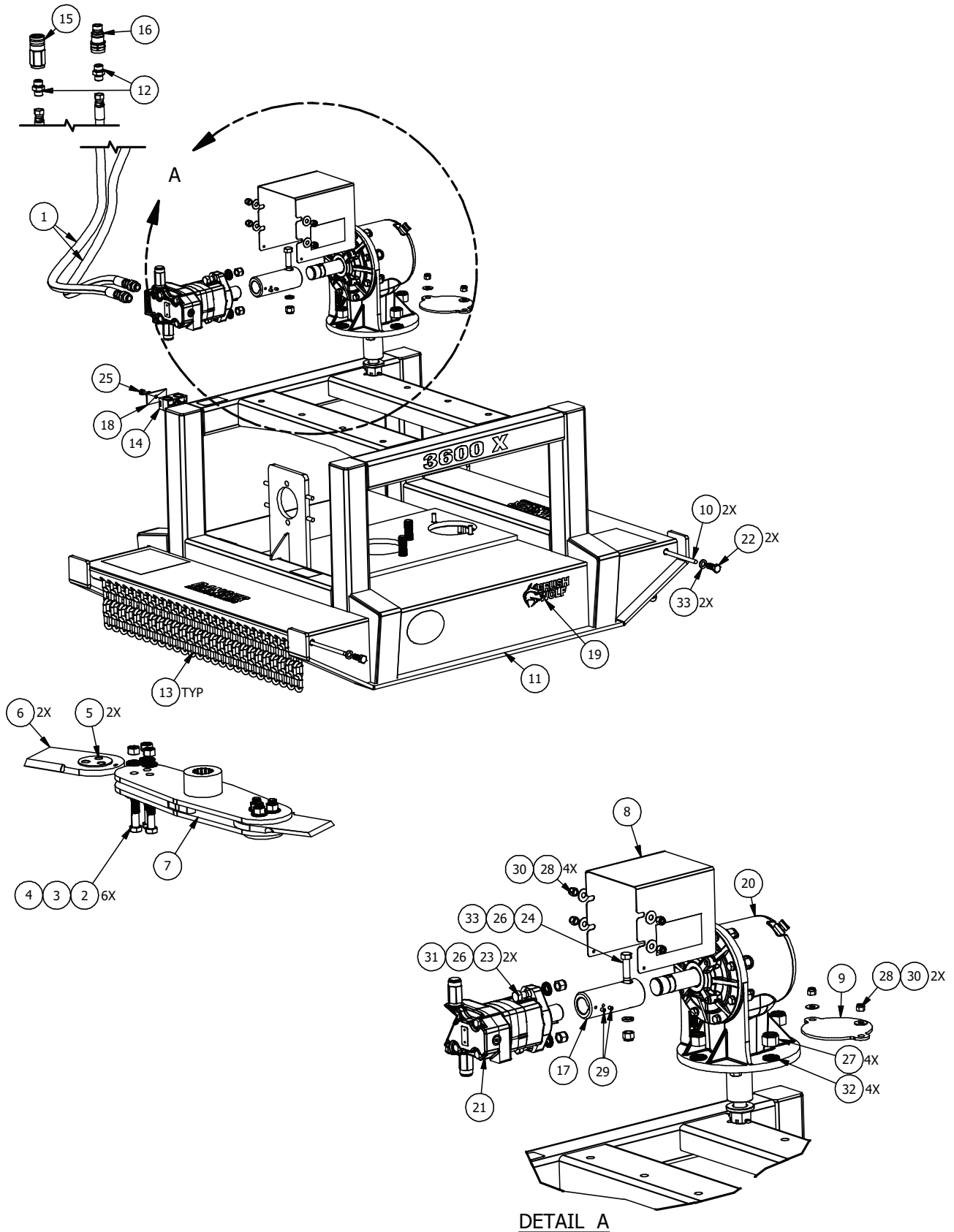

ONLY USE GENUINE OEM PARTS. ORDER PARTS FROM BRUSH WOLF AT **218-692-1050**

ITEM	ITEM QTY	PART NUMBER	DESCRIPTION
1	1	15595	HOSE WHIP ASSEMBLY, -8 ORFS, FEMALE SWIVEL COUPLINGS, 0.500 X 90.000 HOSE
2	6	16149	BOLT 3/4-16x3 GR 8 LONG SHOULDER
3	6	30070	NUT TOPLOCK 3/4-16 GRD8 ZINC
4	6	16148	WASHER, NORD-LOCK, 0.750 X 1.540 OD, ZINC
5	2	15099	PUCK, 3.500 DIA X 0.750, 3 HOLE
6	2	17066	BLADE, FLAT, 18.000 X 8.500 X 0.625
7	1	17069	WELDMENT, BLADE CARRIER, BW 3600X
8	1	15103	GAURD, COUPLING, BW, X MODEL, STD
9	1	17065	PLATE, ACCESS, 2 HOLE, 5.500 DIA
10	2	17075	ROD, ROUND, 0.375 X 35.000
11	1	17052	WELDMENT, FRAME, BW 3600X
12	4	15584	ADAPTER, STRAIGHT, #8 MORFS, #10 MORB
13	52	15285	CHAIN, 0.313, 4 LINK, PROOF COIL
14	1	15263	CLAMP, BODY, TWO PIECE, 22MM, TWO HOSE
15	1	15078	COUPLER, FLAT FACED, 1/2 FEMALE, 7/8-14, O-RING BOSS
16	1	15079	COUPLER, FLAT FACED, 1/2 MALE, 7/8-14, O-RING BOSS
17	1	15123	COUPLING, STD, 1.250 MOTOR, 1.375 GB, 5.500
18	1	15264	COVER PLATE, CLAMP, 22MM, TWO HOSE
19	1	17074	DECAL KIT, 3600X
20	1	15093	GEAR BOX, 62HP, 1:1.93 RATIO
21	1	15352	MOTOR, 4.9 CU IN, SAE "A" 2 BOLT, 7/8-14 SAE O-RING PORTS, 1.250 DIA X 1.250 KEYED
22	2	30024	BOLT, HH, 1/2-13 X 1 1/4 UNC, GRD 5, ZINC
23	2	30026	BOLT, HH, 1/2-13 X 2 UNC, GRD 5, ZINC
24	1	30029*	BOLT, HH, 1/2-13 X 3, GRD 2, ZINC
25	1	30052	BOLT, HH, 5/16-18 X 1 3/4, GRD 5, ZINC
26	3	30062	NUT, NYLOCK, 1/2-13, ZINC
27	4	30064	NUT, NYLOCK, 3/4-10, ZINC
28	6	30065	NUT, NYLOCK, 3/8-16, ZINC
29	2	30078	SET SCREW_CP_1_4-20X3_8 UNC
30	6	30083	WASHER, FLAT, 3/8, ZINC
31	2	15381	WASHER, NORD-LOCK, 0.500 X 1.000 OD, ZINC
32	4	15379	WASHER, NORD-LOCK, 0.750 X 1.210 OD, ZINC
33	3	30093	WASHER, SPRING LOCK, .500, ZINC
34	1	30091	WASHER, SPRING LOCK, 5/16, ZINC

* SHEAR BOLT

PARTS: 4200X

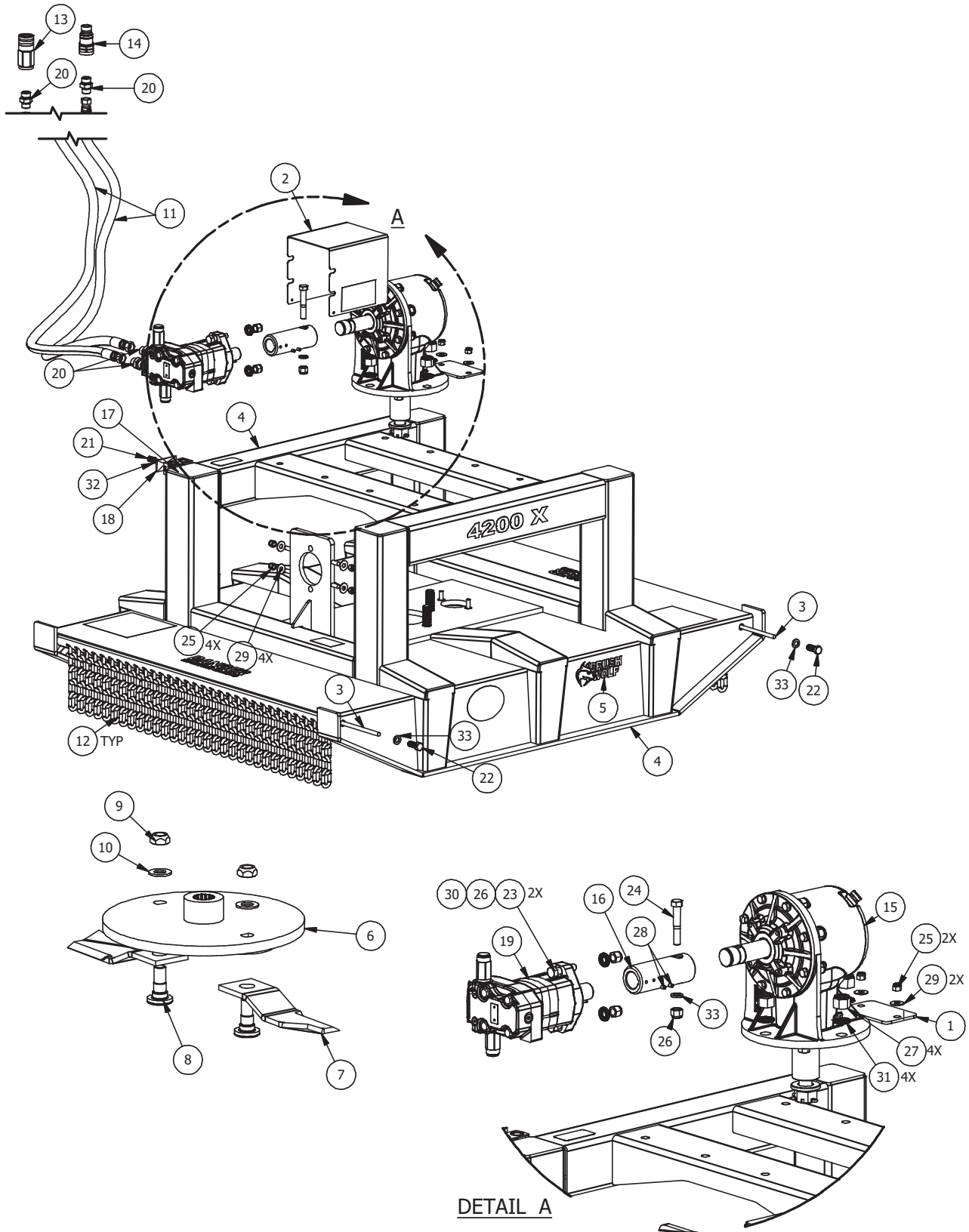

ONLY USE GENUINE OEM PARTS. ORDER PARTS FROM BRUSH WOLF AT **218-692-1050**

ITEM	ITEM QTY	PART NUMBER	DESCRIPTION
1	1	15054	PLATE, ACCESS, 2 HOLE, 5.250 X 3.250 X 0.250
2	1	15103	GAURD, COUPLING, BW, X MODEL, STD
3	2	15108	ROD, ROUND, 0.375 X 41.000
4	1	15151	WELDMENT, FRAME, BW 4200X
5	1	15132	DECAL KIT, BW 4200X
6	1	15167	WELDMENT, BLADE CARRIER, 20.000 DIA X 1.000
7	2	15265	BLADES, 14.750 X 4.000 X .500
8	2	15066	BOLT, D-BOLT, 1 1/8-12, BW
9	2	15148	NUT, TOP LOCK, 1 1/8-12, GRADE C, PLAIN
10	2	30089	WASHER, FLAT, 1 1/8, F436, ZINC
11	2	15595	HOSE WHIP ASSEMBLY, -8 ORFS, FEMALE SWIVEL COUPLINGS, 0.500 X 90.000 HOSE
12	62	15068	CHAIN, 0.313, 5 LINK, PROOF COIL
13	1	15078	COUPLER, FLAT FACED, 1/2 FEMALE, 7/8-14, O-RING BOSS
14	1	15079	COUPLER, FLAT FACED, 1/2 MALE, 7/8-14, O-RING BOSS
15	1	15093	GEAR BOX, 62HP, 1:1.93 RATIO
16	1	15123	COUPLING, STD, 1.250 MOTOR, 1.375 GB, 5.500
17	1	15263	CLAMP, BODY, TWO PIECE, 22MM, TWO HOSE
18	1	15264	COVER PLATE, CLAMP, 22MM, TWO HOSE
19	1	15352	MOTOR, 4.9 CU IN, SAE "A" 2 BOLT, 7/8-14 SAE O-RING PORTS, 1.250 DIA X 1.250 KEYED SHAFT, 3500/750 RELIEF, EATON
20	4	15584	ADAPTER, STRAIGHT, #8 MORFS, #10 MORB
21	1	30052	BOLT, HH, 5/16-18 X 1 3/4, GRD 5, ZINC
22	2	30024	BOLT, HH, 1/2-13 X 1 1/4 UNC, GRD 5, ZINC
23	2	30026	BOLT, HH, 1/2-13 X 2 UNC, GRD 5, ZINC
24	1	30029*	BOLT, HH, 1/2-13 X 3, GRD 2, ZINC
25	6	30065	NUT, NYLOCK, 3/8-16, ZINC
26	3	30062	NUT, NYLOCK, 1/2-13, ZINC
27	4	30064	NUT, NYLOCK, 3/4-10, ZINC
28	2	30078	SET SCREW_CP_1_4-20X3_8 UNC
29	6	30083	WASHER, FLAT, 3/8, ZINC
30	2	15381	WASHER, NORD-LOCK, 0.500 X 1.000 OD, ZINC
31	4	15379	WASHER, NORD-LOCK, 0.750 X 1.210 OD, ZINC
32	1	30091	WASHER, SPRING LOCK, 5/16, ZINC
33	3	30093	WASHER, SPRING LOCK, .500, ZINC

* SHEAR BOLT

PARTS: 4800X LF | 4800X SF

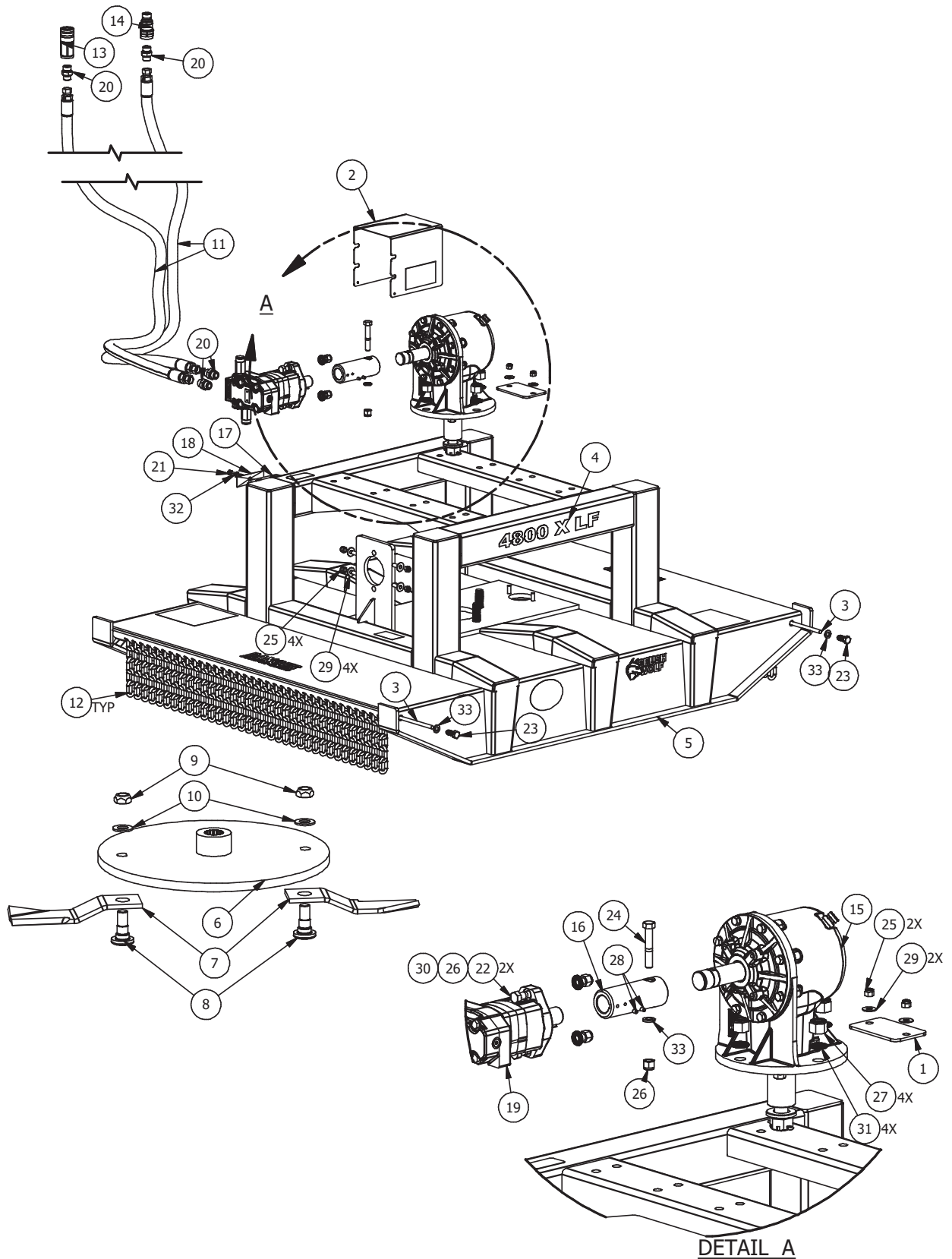

ONLY USE GENUINE OEM PARTS. ORDER PARTS FROM BRUSH WOLF AT **218-692-1050**

ITEM	ITEM QTY	PART NUMBER	DESCRIPTION
1	1	15054	PLATE, ACCESS, 2 HOLE, 5.250 X 3.250 X 0.250
2	1	15103	GAURD, COUPLING, BW, X MODEL, STD
3	2	15109	ROD, ROUND, 0.375 X 47.000
4	1	15376*	LOW FLOW BRUSH CUTTER - DECAL KIT, BW 4800X LF
4	1	15134*	STANDARD FLOW BRUSH CUTTER -DECAL KIT, BW 4800X
5	1	15171	WELDMENT, FRAME, BW 4800X
6	1	15179	WELDMENT, BLADE CARRIER, 26.000 DIA X 1.000
7	2	15265	BLADES, 14.750 X 4.000 X .500
8	2	15066	BOLT, D-BOLT, 1 1/8-12, BW
9	2	15148	NUT, TOP LOCK, 1 1/8-12, GRADE C, PLAIN
10	2	30089	WASHER, FLAT, 1 1/8, F436, ZINC
11	2	15593	HOSE WHIP ASSEMBLY, -8 ORFS, FEMALE SWIVEL COUPLINGS, 0.750 X 90.000 HOSE
12	70	15068	CHAIN, 0.313, 5 LINK, PROOF COIL
13	1	15078	COUPLER, FLAT FACED, 1/2 FEMALE, 7/8-14, O-RING BOSS
14	1	15079	COUPLER, FLAT FACED, 1/2 MALE, 7/8-14, O-RING BOSS
15	1	15093	GEAR BOX, 62HP, 1:1.93 RATIO
16	1	15123	COUPLING, STD, 1.250 MOTOR, 1.375 GB, 5.500
17	1	15248	CLAMP, BODY, TWO PIECE, 30MM, TWO HOSE
18	1	15249	COVER PLATE, CLAMP, 30MM, TWO HOSE
19	1	15352*	LOW FLOW BRUSH CUTTER - MOTOR, 4.9 CU IN, SAE "A" 2 BOLT, 7/8-14 SAE O-RING PORTS, 1.250 DIA X 1.250 KEYED SHAFT, 3500/750 RELIEF, EATON
19	1	15353*	STANDARD FLOW BRUSH CUTTER - MOTOR, 6.2 CU IN, SAE "A" 2 BOLT, 7/8-14-12 SAE O-RING PORTS, 1.250 DIA X 1.250 KEYED SHAFT, 3500/750 RELIEF, EATON
20	4	15584	ADAPTER, STRAIGHT, #8 MORFS, #10 MORB
21	1	30053	BOLT, HH, 5/16-18 X 2 1/2, GRD 5, ZINC
22	2	30026	BOLT, HH, 1/2-13 X 2 UNC, GRD 5, ZINC
23	2	30024	BOLT, HH, 1/2-13 X 1 1/4 UNC, GRD 5, ZINC
24	1	30029**	BOLT, HH, 1/2-13 X 3, GRD 2, ZINC
25	6	30065	NUT, NYLOCK, 3/8-16, ZINC
26	3	30062	NUT, NYLOCK, 1/2-13, ZINC
27	4	30064	NUT, NYLOCK, 3/4-10, ZINC
28	2	30078	SET SCREW_CP_1_4-20X3_8 UNC
29	6	30083	WASHER, FLAT, 3/8, ZINC
30	2	15381	WASHER, NORD-LOCK, 0.500 X 1.000 OD, ZINC
31	4	15379	WASHER, NORD-LOCK, 0.750 X 1.210 OD, ZINC
32	1	30091	WASHER, SPRING LOCK, 5/16, ZINC
33	3	30093	WASHER, SPRING LOCK, .500, ZINC

* DEPENDS ON THE MODEL OF BRUSH CUTTER

** SHEAR BOLT

PARTS: 4800X HF

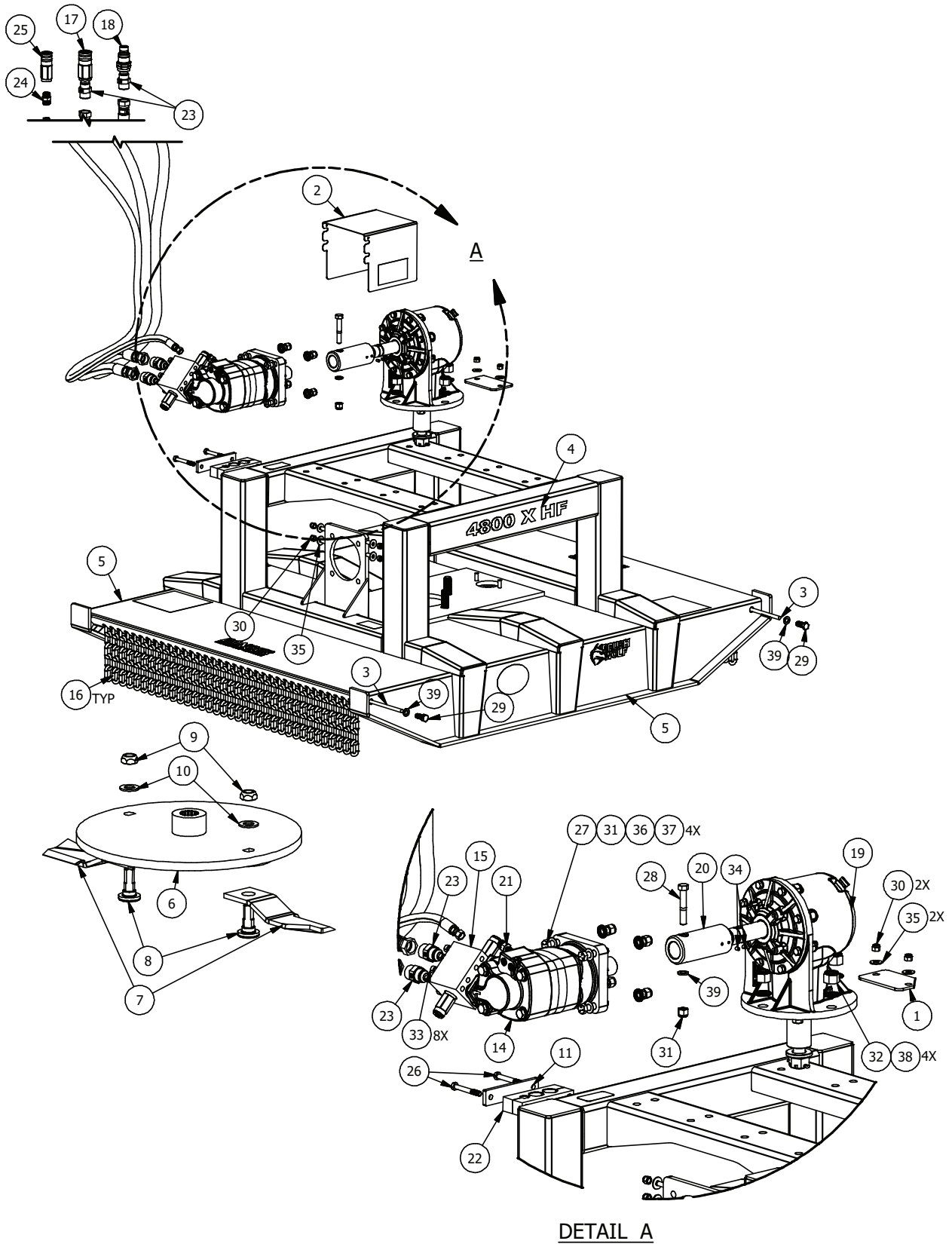

ONLY USE GENUINE OEM PARTS. ORDER PARTS FROM BRUSH WOLF AT **218-692-1050**

ITEM	ITEM QTY	PART NUMBER	DESCRIPTION
1	1	15054	PLATE, ACCESS, 2 HOLE, 5.250 X 3.250 X 0.250
2	1	15104	GUARD, COUPLING, BW, X MODEL, HF
3	2	15109	ROD, ROUND, 0.375 X 47.000
4	1	15350	DECAL KIT, BW 4800X HF
5	1	15311	WELDMENT, FRAME, BW 4800X HF
6	1	15179	WELDMENT, BLADE CARRIER, 26.000 DIA X 1.000
7	2	15265	BLADES, 14.750 X 4.000 X .500
8	2	15066	BOLT, D-BOLT, 1 1/8-12, BW
9	2	15148	NUT, TOP LOCK, 1 1/8-12, GRADE C, PLAIN
10	2	30089	WASHER, FLAT, 1 1/8, F436, ZINC
11	1	15418	PLATE, STAUFF, 3 HOLE COVER, 1.25 X 5.875
12	2	15590	HOSE WHIP ASSEMBLY, -12 ORFS, FEMALE SWIVEL COUPLINGS, 0.750 X 90.000 HOSE
13	1	15591	HOSE WHIP ASSEMBLY, -6 ORFS, FEMALE SWIVEL COUPLINGS, 0.375 X 96.000 HOSE
14	1	15149	MOTOR, 11.9 CU IN, SAE "CC" 4 BOLT, 0.750 DIA SPLIT FLANGE STAGGERED PORTS, 1.500 DIA X 1.625 KEYSHAFT BW
15	1	15125	BLOCK, CROSSOVER RELIEF MANIFOLD, 6K MOTOR, ALUMINUM
16	70	15068	CHAIN, 0.313, 5 LINK, PROOF COIL
17	1	15114	COUPLER, FLAT FACED, 5/8 FEMALE, 1 1/6-12, O-RING BOSS
18	1	15115	COUPLER, FLAT FACED, 5/8 MALE, 1 1/6-12, O-RING BOSS
19	1	15092	GEAR BOX, 62HP, 1:1.46 RATIO
20	1	15053	COUPLING, HF, 1.500 MOTOR, 1.375 GB, 5.500
21	1	15407	ADAPTER, STRAIGHT, #6 MORFS, #4 MORB
22	1	15401	CLAMP, BODY, TWO PIECE, 30-30-18, THREE HOSE, BLACK
23	4	15405	ADAPTER, STRAIGHT, #12 MORF, #12 MORB
24	1	15408	ADAPTER, STRAIGHT, #6 MORFS, #8 MORB
25	1	15414	COUPLER, FLAT FACED, 3/8 FEMALE, 3/4-16, O-RING BOSS
26	2	30044	BOLT, HH, 3/8-16 X 3, GRD 5, ZINC
27	4	30025	BOLT, HH, 1/2-13 X 2 1/2 UNC, GRD 5, ZINC
28	1	30029*	BOLT, HH, 1/2-13 X 3, GRD 2, ZINC
29	2	30024	BOLT, HH, 1/2-13 X 1 1/4 UNC, GRD 5, ZINC
30	6	30065	NUT, NYLOCK, 3/8-16, ZINC
31	5	30062	NUT, NYLOCK, 1/2-13, ZINC
32	4	30064	NUT, NYLOCK, 3/4-10, ZINC
33	8	30076	SCREW, SHCS, 3/8-16 X 3 1/2 GRD8
34	2	30078	SET SCREW_CP_1_4-20X3_8 UNC
35	6	30083	WASHER, FLAT, 3/8, ZINC
36	4	30084	WASHER, FLAT, 1/2, ZINC
37	4	15381	WASHER, NORD-LOCK, 0.500 X 1.000 OD, ZINC
38	4	15379	WASHER, NORD-LOCK, 0.750 X 1.210 OD, ZINC
39	3	30093	WASHER, SPRING LOCK, .500, ZINC

* SHEAR BOLT

WARRANTY INFORMATION

PROTECT YOUR PURCHASE.

Warranties are valid from date of purchase with a warranty registration on file. Scan the QR code below or go to brushwolf.com/warranty to file a claim and view warranty details.

5 YEAR
LIMITED
WARRANTY

Structural Components • Materials • Weldment

1.5-YEAR LIMITED WARRANTY

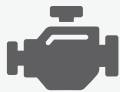

Hydraulic Motor



Gearbox



Bearing Housing

